

# Working and Joining Instructions for Noiseless metal

## WORKING

### Note carefully before starting work:

NM (Noiseless Metal) panels must be near room temperature before being worked. If the panel is too far below room temperature, bending and similar operations may cause delamination.

## CUTTING

NM panels are easily cut with guillotine shears. Cutting edges should be well sharpened. Set the clearance between the cutting edges to that which would be used for a sheet of half the thickness of the NM panel. Asymmetrical panels (i.e. with facings of unequal thickness) should be cut with the thinner facing upwards. Cutting methods must be avoided which cause excessive heating of the panel, such as flame cutting and cutting with a cutting wheel. However, NM has been cut successfully with both laser and plasma cutters. Band saws are also used for cutting NM parts.

## BENDING AND FLANGING

NM panels can be bent and flanged without trouble, provided that a few essential points are borne in mind. The bending radius should be at least 1.5 - 2 times the thickness of the panel.

When the NM panel is bent it behaves rather like two sheets of metal lying loosely one on top of the other, and the facings are displaced by the difference in bending radius between the inner and outer facing.

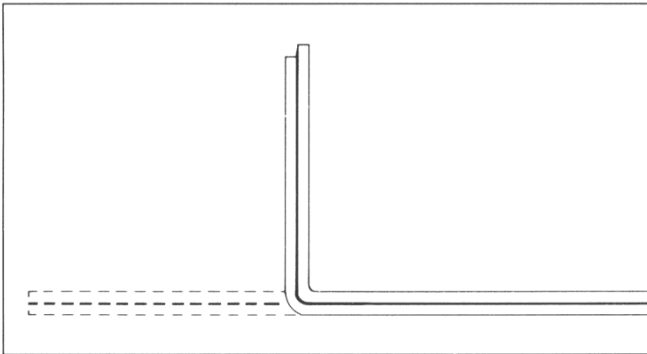

The amount of the displacement depends on the type of inner layer, the thickness of the facings, the bend angle and the distance to the edge of the panel. The displacement is greatest when a thick sheet is bent to a large angle close to the edge of the sheet, when it can amount to several millimeters.

As a result of displacement, several successive bends cannot be made without certain precautions being taken (see below). Always bend nearest a free edge to allow for displacement. If you bend on the side nearest a bent edge, the layers of the panel will split apart.

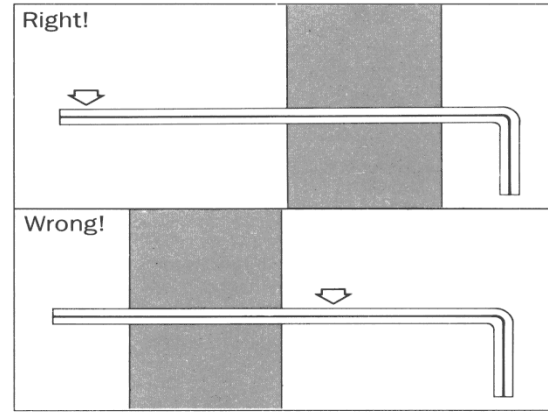

When bending heavier NM panels, more than 0.080" (2mm) thick, and delamination can occur if the bend is made away from the nearest edge. Instead of delamination, the flat panel outside the bend can assume a bow shape, reminiscent of a seagull's wing. If these phenomena occur, please contact American Acoustical Products.

## DEEP DRAWING

NM panels of deep drawing quality should be used for this type of forming. In most cases, NM requires a higher blank holding force than homogeneous sheet of equal thickness. On the other hand, too high a force may result in cracking. Thus the "window" between too low and too high blank holding force is narrower for an NM panel than for a conventional sheet. For further information regarding deep drawing, please contact American Acoustical Products.

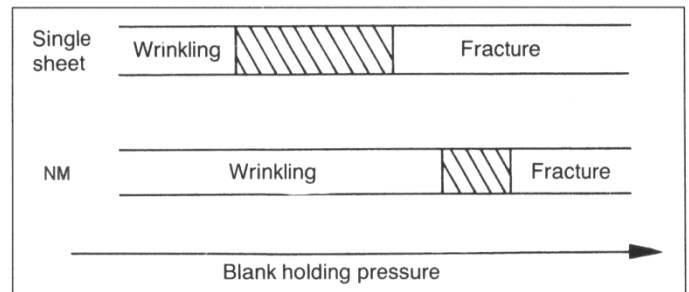

## BEADING AND EMBOSSING

These operations can be performed in the same way as with single sheets of metal. Because the operation takes place under compressive force, there is no risk of separation at the edges of the panel.

## PUNCHING AND DRILLING

Any drilling or piercing should be done after forming, as otherwise the holes will be displaced. The clearance of punching and piercing tools should be calculated in the same way as for cutting.

## JOINING AND FASTENING

NM panels are readily joined by both resistance and arc welding. American Acoustical Products and leading

manufacturers of welding equipment have made exhaustive tests of both methods.

In all welding operations, both the duration and heating of the thermoplastic inner layer should be kept to a minimum. In special cases it may be necessary to cool the panel with cooling pastes, copper bars, strips of wet felt etc. Spots of molten plastic on the metal surfaces can be cleaned off with acetone, trichloroethylene and many other solvents. Complete immersion in the organic solvents should however be avoided.

## RESISTANCE WELDING

NM panels lend themselves well to resistance welding. The strength of the joint is equivalent to that normally obtained in solid sheet welding.

Before resistance welding begins, a current path must be created between the two skin sheets in the pile to be welded. For this purpose, a clamp or pliers may be used. An electrical connecting bridge can also be an integrating part in a fixture. Once electrical contact has been established between the metal facings no further clamping is needed.

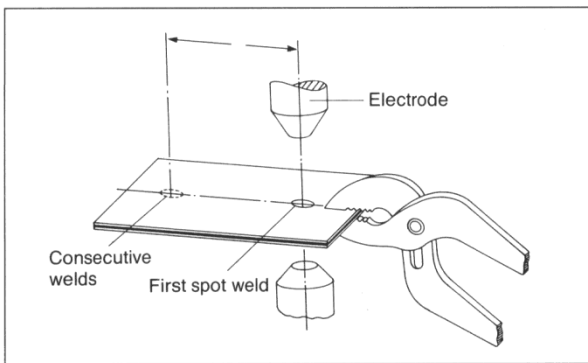

On most welding machines the AWS Recommended Practices for Resistance Welding, AWS C1.1, also gives proper welds on NM panels. Sheet thickness is the thickness of the panel. When the distance between the welds is more than 75mm, it may be necessary to increase the welding time by 3 to 5 cycles, thus giving the inner layer enough time to melt.

Seam welding, continuous or intermittent, is also a suitable method, but the NM panel must be cooled with water which is poured on directly at the welding spot. To start the welding, a heavy clamp or a previously made spot weld is used as an electrical connecting bridge. Projection welding, a good method of attaching welding studs and brackets, also requires a very good electrical bridge capable of carrying the whole current for a couple of periods.

Bolts can be attached by stud welding, but are welded only to the sheet facing the bolts.

## ARC WELDING

Shielded metal-arc welding. NM panels with thickness of 2 mm or more can be welded with coated electrodes, preferably the basic type. In all other cases MIG, MAG or TIG procedures should be used

Some difficulty may be experienced due to gases evolved by melting plastic interfering with the flow of

shielding gas. Molten plastic may also run into the joint, resulting in porosity and making the welding process difficult to control. In most cases, CO<sub>2</sub> or a mixture of CO<sub>2</sub> and argon (Ar) is used. The operation is made easier if the gas flow is increased slightly and the welding pistol angles away from the weld (Forehand Welding)

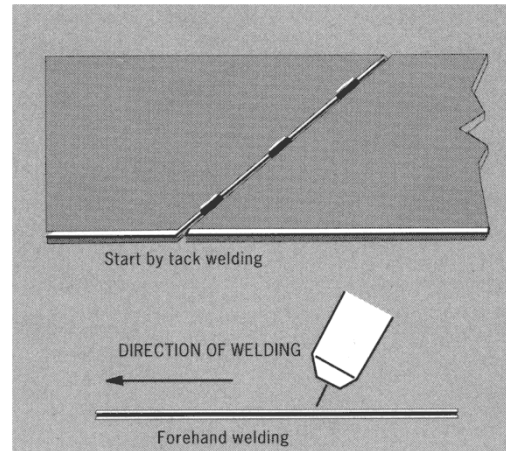

Thin NM panels are normally welded in lap joints. When one NM panel is to be welded to a homogeneous sheet, the best results are obtained if the NM panel is placed on the normal sheet and a fillet weld is placed at the edge of the NM panel, see fig.

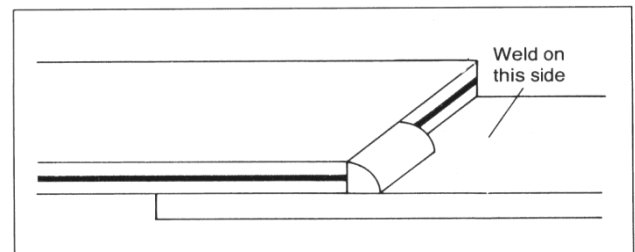

Lap joint

If the weld is made close to the edge of the NM panel, the gases from the plastic can easily escape and do no harm. On the other hand, welding NM off edges may result in an internal pressure being built up between the facings of the NM panel. To prevent the facing sheets from separating during welding, it is recommended that spot welds be made (by arc or resistance welding) along the site of the joint.

In butt, lap and tee-joints, welding data must be selected according to the thickness of the individual facing. In edge joints on heavier gauge material, the data should be selected on the basis of the thickness of the whole NM panel. It is always advisable to make practical tests in each individual case.

## BRAZING, GAS AND LASER WELDING

Laser welding can be done on lap joints when an NM panel is welded to a homogeneous sheet. The NM panel must be placed towards the laser beam.

Gas welding is not a suitable method of joining NM panels. The only exceptions are small-scale repair or edge fixing jobs. More extensive welding causes the plastic inner layer to break down and vaporize. Brazing

cannot be done for the same reason. An alternative method to brazing is soldering.

## VARIOUS TYPES OF JOINT

Fillet welding to a heavier gauge material or between NM panels: first secure the edges of the NM panel with tack welds.

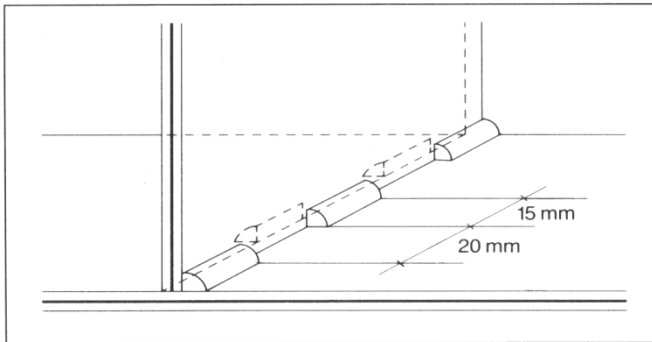

*Tee joint*

Continuous fillet welds should be made step by step (see butt welding). Welds 15 mm long and 20 mm apart will suffice. Intermittent fillet welding to a zigzag pattern gives the best result.

Butt welding: here, too, the edges of the NM panels should first be secured by tack welds. The butt weld should be built up step by step as illustrated.

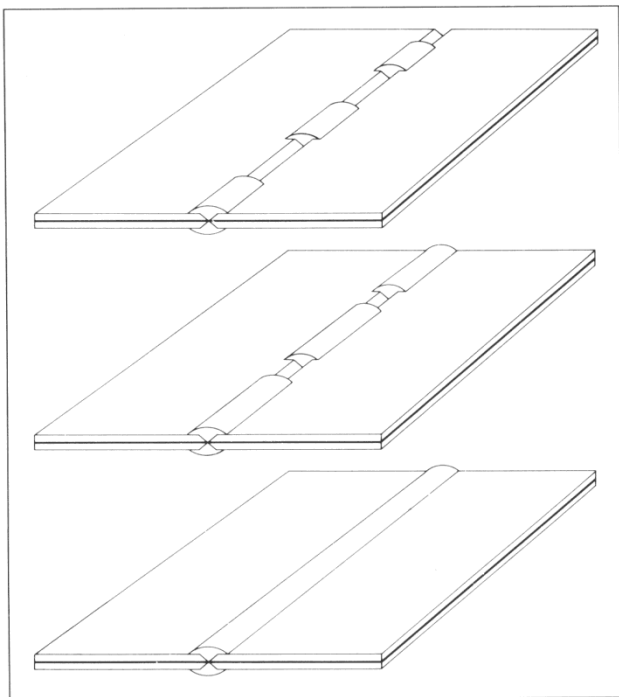

*Butt joint*

Corner welding: locate the panels so that there is a gap between them, make tack welds and build up the continuous weld in the same way as butt welds.

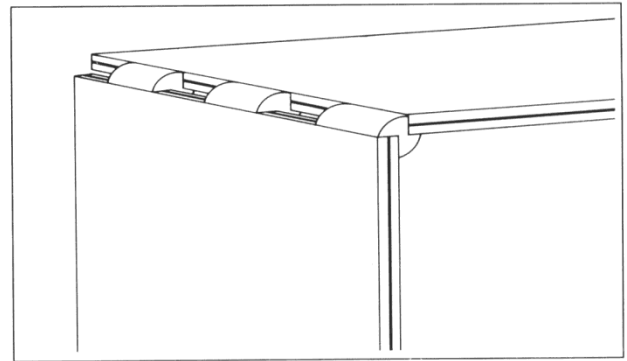

*Corner joint*

## SOLDERING

Soldering is a suitable method for attaching pipe connections in flanged holes, for instance.

## MECHANICAL FASTENING

NM panels can be fastened with screws, bolts and rivets just like solid metal sheets. The fixings should, however, be more closely spaced owing to the lower flexural rigidity of NM panels compared to solid sheets of the same dimensions.

## LASER CUTTING

Cutting any metal with a laser, is much like arc welding or flame cutting on metal. In most if not all states, this is legal as long as the fumes emitted from the operation do not exceed OSHA's Permissible Exposure Limits for metal fumes, especially zinc. Some states may have lower limits than OSHA for these metal fumes. Ventilation must always be used, and metal fume sampling should have been conducted to verify exposure levels. Every state has at least one OSHA office and one State run OSHA Consultation Office you can call with questions. In many cases, you can contact the State Consultation Office and they will conduct the sampling for free if you agree to correct any hazards identified during the visit. This website [www.osha.gov](http://www.osha.gov) will allow you find the contact information for each state and contains information on metal fumes, welding, cutting etc. Regarding the inner layer, tests by independent consultants have detected no elements in the fumes that are not present in normal welding of steel with mill oil coatings. However due to the potential quantity of fumes from the decomposition of the inner layer we strongly recommend efficient ventilation to remove the odor.

## PAINTING PROCESSES

Standard painting procedures can be used to paint NM components. Normal cleaning and metal passivation treatments will have no adverse effect on NM, and both spraying and electro-coating are acceptable painting methods. The temperature resistance in paint curing ovens is about 360°F(180°C) for all our NM laminates. Some of our laminates have an even higher temperature resistance, and American Acoustical Products should be consulted for advice if higher oven temperatures are used